

CONTENTS

Safety precautions 18-22
 Specification & description 23
 New maschine 24
 Attaching Rotavator to the tractor 25
 Lever change gearbox 26
 Rotors 27
 Blading 27
 Changing rotors 27
 Depth control- cooling & lubrication circuit 28
 Toothed roller use 28
 Lubrication + maintenance 29
 Adjustments 29
 Operating instructions 30
 Optional equipment 31
 Operating checklist 32

Introduction

Howard would like to thank you for purchasing this Rotavator and offer their support and assistance throughout its productive life.

This Rotavator has been designed and manufactured as a tractor driven, ground cultivator - no other use is intended.

Please read and understand this manual before operating the Rotavator.

Warranty

The warranty applicable to your machine is detailed on separate documentation which should accompany this manual. If this is missing, please contact your dealer.

Serial Number

The Serial Number and Model are stamped on the Identification Plate attached to your Rotavator. For future reference record this information below. Always quote them when ordering spare parts.

MODEL _____

SERIAL No. _____

Date Purchased: _____

SAFETY PRECAUTIONS



**PLEASE READ. IT MAY SAVE A LIFE.
SAFETY IS YOUR RESPONSIBILITY.**

The safety of operators and any other connected personnel is a major component of; machine design, manufacture, retailing, commissioning, operation and maintenance. Howard have designed and manufactured this Rotavator with as many safety features as possible. The retailer's responsibility is to ensure you have selected the correct Rotavator for your tractor/application and to commission this machine.

Your responsibilities as owner or operator are to ensure the safety of any personnel in connection with; the operation, transport, maintenance or storage of this Rotavator. Be aware of your responsibilities and carry them out. The owner or an appropriately designated officer, if the owner is a company or corporation, is responsible for all safety issues related to this Rotavator.

The most important safety device attached to this Rotavator is a Safety Conscious Operator whose training and experience must include:

- Correct and complete installation and commissioning of the machine to ensure safe and reliable operation in the intended application.
- Training in safety issues, operation and maintenance of this machine in its application prior to beginning work. This training is to be reviewed or repeated annually.
- Being aware of their environment to the extent that unforeseen safety issues that may arise are dealt with to ensure the safety of all personnel (including operators, maintenance personnel and bystanders).

This is the SAFETY ALERT symbol and means:



ATTENTION ! SAFETY ISSUE !

Failure to comply with the given instruction could result in severe injury or death.

If you have questions not answered in this manual please contact your dealer or distributor.

If you require more copies of this manual please contact your dealer. Alternatively you are welcome to copy and distribute this manual to the operators and maintenance personnel.

SAFETY DECAL LOCATION

Explanations of pictogram decals (Fig 1).

Note: Decals may differ slightly from those shown.

P/N 187250 Read Manual !

Prior to operating machine, read the operator's manual and observe all safety instructions.

P/N 629551 Shut off engine !

Shut off engine and remove key before performing maintenance or repair work.

P/N 629548 Flying Objects !

Keep safe distance from the machine as long as the engine is running.

P/N 624367 Revolving Rotor !

Stay clear of the rotor area as long as the tractor engine is running and the PTO connected.

P/N 209095260 Drive Shaft Entanglement !

Keep clear of and also keep loose clothing away from rotating PTO shaft to avoid entanglement.

- Ensure that these decals are always legible and that they are replaced immediately if they are damaged, lost or their supporting parts are replaced. Decals can be ordered from your dealer.

SAFETY DECAL CARE

- Keep safety decals clean and legible at all times. Replace any missing safety decals or any that have become illegible. Safety decals can be purchased from you dealer or distributor.
- If any part is replaced that supports a safety decal ensure that a decal is affixed to the replacement part.

ATTACHING SAFETY DECALS

1. Clean and dry the area where the decal is to be affixed. Warm soapy water is the best as some cleaning agents leave an oily film which may prevent the decal adhering.
2. Remove/fold back a small portion of the backing and affix the exposed portion of the decal in the desired position.
3. Peel back the remaining backing paper from under the decal and smooth down the decal with a rag, working any bubbles towards the edge of the decal.
4. Any bubbles that remain trapped can be pierced with a pin and smoothed down.

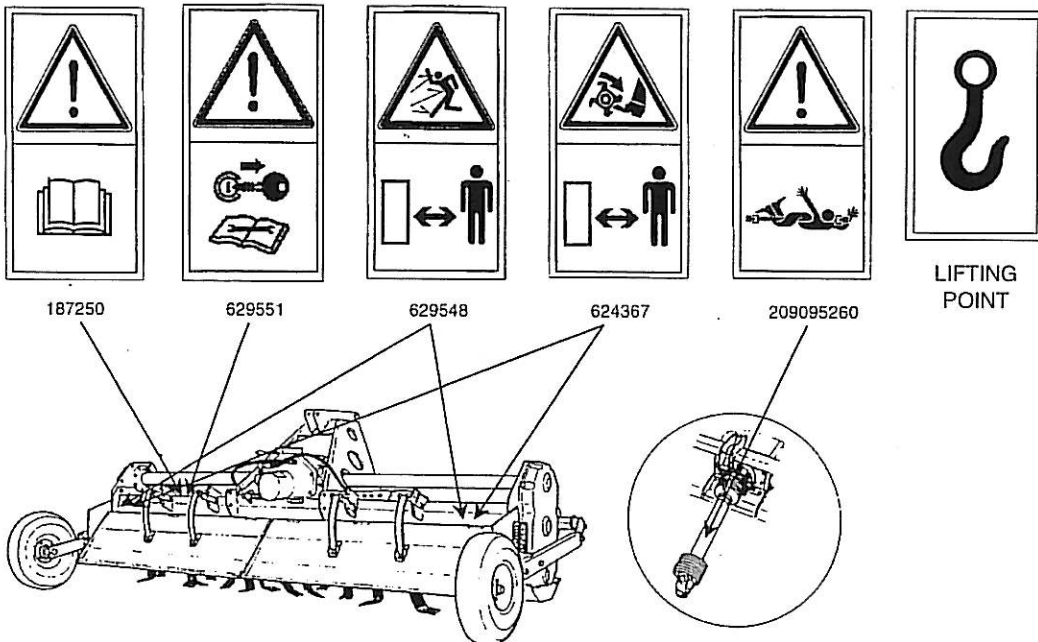

Fig. 1

AT ALL TIMES

- Use the Rotavator only for the purpose for which it has been designed, and in accordance with the instructions in this operators manual.
- Ensure that only responsible, properly instructed people operate this machinery. Inexperienced operators will require training, followed initially by careful supervision.
- Children are not permitted to operate this machinery.
- Keep children well clear and appropriately supervised when connecting/disconnecting the tractor, operating or maintaining this machinery.
- Do not wear clothes that are loose fitting or with drawstring ties which can catch in moving parts.
- Wear appropriate protective clothing and equipment. Boots are a minimum, however if your tractor is not fitted with a controlled environment cab you may also need protection from prolonged exposure either to noise, dust or sunlight.
- Interpret 'Left' and 'Right' as if seated in the operators seat and facing forward.

BEFORE OPERATION

- Read and understand this manual.
- The tractor to be connected to the Rotavator:
 - Must be the tractor that the Rotavator has been commissioned to operate with. Check that it has been correctly maintained and has not been re-configured (for example front weights removed etc) which may reduce stability and control.
 - Consult the Tractor Manufacturers Manual for instructions on mounting implements and safe working methods.
 - Is recommended to be fitted with a Roll Over Protection System (ROPS).
 - Must be one the operator is familiar with.
- Prior to starting the tractor ensure the PTO is disengaged and the tractor is in neutral.
- Do not allow anyone to stand between the tractor and Rotavator while backing the tractor up to attach it.
 - Quick hitch systems are recommended for both Safety and convenience.
 - Before attempting to connect the universal drive shaft to the tractor, lower the Rotavator to the ground, stop the tractor, apply the park brake and remove the key.
- Visually inspect the Rotavator and check:
 - Hitch pins and drive shaft are secure.
 - No components are excessively worn, cracked or otherwise defective and all bolts are tight.
 - Guards, covers, warning labels and safety devices are all correctly fitted and operative.
 - Maintenance as per schedule has been carried out.
 - No tools or other unsecured items have been left on the Rotavator.
- Practice operation of the tractor and Rotavator combination.
 - Take sufficient time to become completely familiar with all controls, particularly those required to bring both tractor and Rotavator to an emergency stop if so required.
 - Progress slowly initially and check stability, steering and braking are satisfactory.

- Ensure the work area is clear, especially of children or animals.
- Inspect the work area for hidden obstructions which may constitute a hazard.

DURING OPERATION

- Ensure the work area is clear, especially of children or animals.
- Do not attempt to start the tractor or engage the PTO until correctly seated in the driver's seat.
- Never leave the tractor running unattended.
- Do not allow passengers on the Rotavator. [Or on the tractor unless approved seating is available.]
- Never attempt to make adjustments or perform maintenance functions while the Rotavator is operating.
- Observe all safe driving procedures:
 - Reduce speed when working on sloping ground or during sharp turns.
 - Do not attempt to work on steeply sloping ground where there is a risk of the tractor overturning.
 - Do not attempt to work near the edge of drop-offs or banks.
 - Avoid sudden starts and stops.
- After striking an obstacle, stop the tractor and implement and inspect it for damage. Repair as necessary before continuing.
- Disengage the PTO when transporting the implement or when not in use.
- When halting operation, even temporarily, lower the Rotavator to the ground, stop the tractor, apply the park brake and remove the key.
- Allow the Rotavator sufficient time to cool down before performing any maintenance, or changing gears in the Selectaspeed gearbox. [Oil and other transmission components may be hot enough to inflict burns.]
- Note:
 - By virtue of its mode of operation it is not possible to totally enclose a Rotavator with guards.
 - Contact with the blades while operating can result in severe injury or death.
 - Do not allow anybody (operators, maintenance personnel, bystanders or especially children) anywhere near the blades whilst the implement is operating. Note that children will often be attracted to placing objects into the blades if you leave it running - this machine is not a toy.
 - Be aware that Rotavator blades will not only cut, but drag limbs etc. into further danger.
 - Ensure that all shielding is in place before operating. If guards are removed for maintenance work, ensure they are replaced correctly upon completion. Repair or replace any damaged guards.
 - NEVER place hands or feet under the Rotavator, nor endeavour to make any repairs or adjustments while the blades are rotating; they are capable of inflicting serious injury.
 - NEVER touch the blades or attempt to free any jammed obstacle while the tractor engine is running. The clutch may be slipping and removal of any obstruction may allow the blades to rotate, the result possibly being serious injury.

FOLLOWING OPERATION

- Visually inspect the Rotavator and check:
 - All bolts are tight.
 - That no components are excessively worn, cracked, damaged or otherwise defective.
- Note and organise any maintenance required.
- Allow the Rotavator sufficient time to cool down before performing any maintenance. The gearboxes, lubricant and other transmission components may be hot enough to inflict burns.
- Refer to TRANSPORT SAFETY and STORAGE SAFETY for issues related to travel to/from operation and disconnection of the Rotavator from the tractor.

STORAGE SAFETY

- When unhitching the Rotavator and before leaving the tractor to disconnect the universal drive shaft and remove hitch pins:
 - Check that the PTO drive has been disengaged.
 - Stop the tractor, apply the park brake and remove the key.
- Store the Rotavator away from human activity and in particular do not permit children to play around, or on, stored equipment.
- Store the Rotavator in a dry level area and ensure parkstands and wheels/roller are securely positioned to prevent it tipping, falling over or rolling onto any personnel (particularly children).

MAINTENANCE SAFETY

- Maintain the Rotavator as detailed in the given schedule and check for any damage after use. Poor maintenance is an invitation to trouble.
- Ensure that all shielding is correctly in place when maintenance is completed. Repair or replace any damaged guards. Warning or instruction decals are to be kept in a readable condition; unreadable decals must be replaced.
- NEVER place hands or feet under the Rotavator nor endeavour to make any repairs or adjustments, while the blades are rotating; they are capable of inflicting serious injury.
- If working on the implement whilst it is raised on the tractor's three-point linkage, ensure:
 - That the tractor is turned off and the ignition key is removed to prevent accidental starting.
 - The park brake is engaged and the wheels chocked to prevent the tractor moving.
 - The PTO drive is disengaged.
 - The Rotavator is properly supported by blocks or stands. DO NOT rely on the tractor's hydraulic system to support the implement.
- Modifications or fitment of non genuine replacement parts.
 - If the equipment is modified in any way from the original design, the manufacturer will not accept any liability for any injury or warranty as a result of their use or attempted fitment.
- Fasteners.
 - Fit only the correct replacement fasteners and tighten fasteners to the torque specified in the manual. Incorrect (too weak) fasteners may break when torqued

to the required setting or, if too strong, may induce failures in other components.

- Follow safe workshop practices during any maintenance:
 - Keep working area clean, dry and in particular free of oil spills.
 - Ensure the workshop is adequately ventilated. Do not run the tractor engine inside a closed building. The exhaust fumes can reduce mental alertness initially and will progressively cause death by asphyxiation.
 - Use tools, lifting or jacking equipment suitably capable of the intended task.
 - Ensure electrical equipment is safe to use before operating.
 - A fire extinguisher and first aid kit should be readily accessible during maintenance.
 - Tools, parts and other service equipment must be removed to appropriate storage locations prior to any test running.
 - Do not wear baggy, ill-fitting or frayed clothing when working around transmission components.
 - Wear suitable gloves when handling or working with sharpened cutting elements.
 - Ensure bystanders, especially small children, are kept clear during maintenance or while making any adjustments.
- Hydraulic fluid can be dangerous.
 - When disconnecting any hydraulic fluid line, shut off the hydraulic supply and relieve the hydraulic pressure.
 - Never use hands to locate hydraulic fluid leaks. Escaping hydraulic fluid is capable of cutting and penetrating skin. Use a small piece of cardboard or wood.
 - Minor cuts are susceptible to infection from hydraulic fluid. Gangrene can result. If injured by escaping hydraulic fluid or you suspect you have been infected, seek medical treatment immediately.

TRANSPORT SAFETY

- When transporting the implement on a tractor on public roads ensure that you comply with the relevant regulations.
 - Class of roads permitted for travel may be restricted.
 - Transport may be restricted to daylight or, off peak traffic hours.
 - Signs indicating width may be required.
 - Lights indicating vehicle width if transported within the hours of darkness may be required.
- If in doubt, contact your government department responsible for road transport.
- Secure the Rotavator for transport.
 - Disengage the PTO when transporting.
 - Ensure all hitch pins are correctly fitted with retaining pins.
 - Mechanically secure hydraulic cylinders to prevent cylinders creeping.
 - Observe the tractor manufacturers regulations and recommendations - specifically those relating to:
 - Maximum transport loads.
 - Maximum speed.
 - Passengers

- Do not allow passengers to ride on the tractor unless a specific seat is provided.
- Do not allow anyone to ride on the implement when it is being transported.
- Consider other road users.
 - Plan your route to avoid heavy traffic and peak traffic periods.
 - Be a safe and courteous driver. Give way to oncoming traffic in all situations, including narrow bridges, intersections etc.
- Adopt safe driving practices:
 - Lock tractor brake pedals together. Never use independent braking at transport speeds.
 - Drive at a safe speed to ensure control and ability to stop in an emergency. Ensure the additional weight of the Rotavator on the linkage does not compromise steering and braking - for example front weights or repairs to the brakes may be required if the tractor is not safe to drive.
 - Reduce speed during turns. Tractors have not been designed for fast cornering.
 - Use engine braking when going down hills - do not coast.
 - Do not drink alcohol and drive.
- Watch for obstructions, particularly if over-width.
- Observe any load ratings applicable on bridges.

IDENTIFICATION OF HAZARDS

- Owners and operators must be prepared to assess their; equipment, operators, maintenance procedures and applications to identify safety hazards.
- Appropriate methods to reduce the hazards identified must then be applied.

MACHINE SUITABILITY TO APPLICATION

Rotavators have been designed and manufactured as a tractor driven, ground cultivator - no other use is intended. However over the years some models have been adapted for new uses, such as road-base preparation and semi-industrial mixing operations.

- Before beginning work it is necessary to assess the effect of the machine on the safety of both the operator and any potential bystanders. It is recommended that you contact the manufacturer or distributor for assistance in this area.

AUTHORISED OPERATORS & TRAINING

If you are an employer, do not assume an operator is trained for use of this equipment, (you would not let an unlicensed driver borrow your car!).

- Ask to see licences if applicable, and record numbers and validity dates.
- Request details of previous experience, in writing and check them out if appropriate and ensure such records are retained.
- Devise a suitable training course for operators if appropriate, and ensure records of their completion are retained.

MAINTENANCE RECORDS

Recommended maintenance is detailed in the Lubrication & Maintenance section. Failure to follow these may jeopardise safety as well as economic operation. Records of periodic maintenance are important as they detail when and who carried out the last maintenance and inspection. Appropriate checklists should include maintenance as detailed and in particular the following safety aspects:

- SAFETY DECALS AFFIXED & LEGIBLE.
- GUARDING - All fitted and secure.
- CRITICAL FASTENERS SECURE

! Fit all safety guards before operating. Operation is not permitted without safety guards fitted. These are not fitted at the factory due to freight limitations.

SAFETY GUARDS

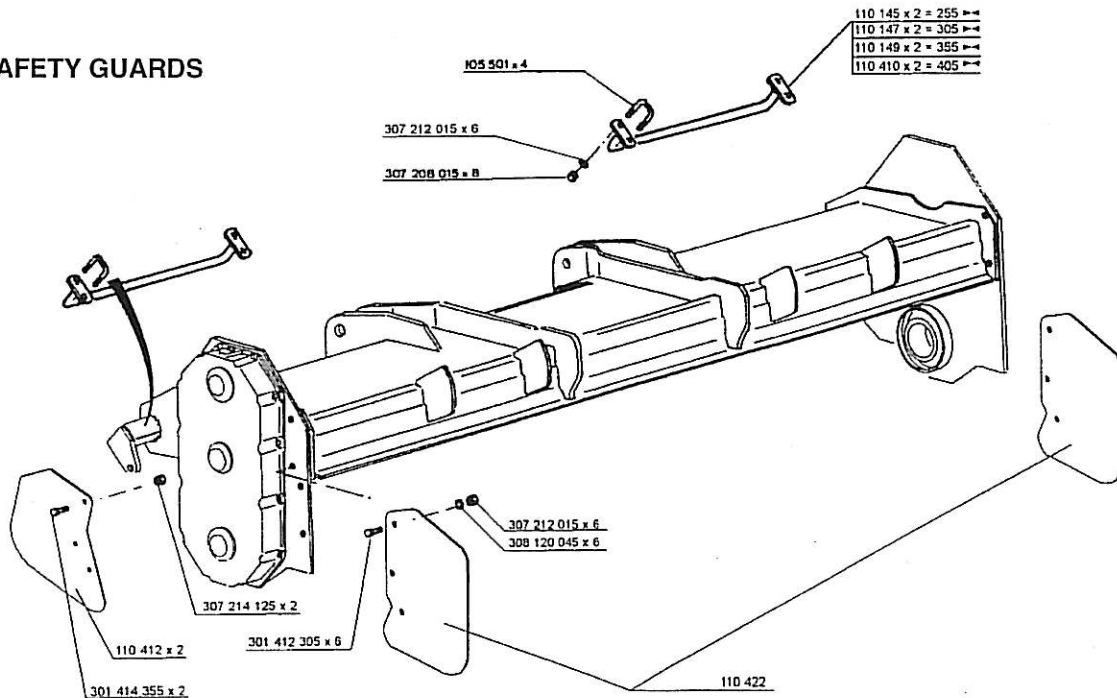

ENGLISH

NEVER

- Touch any moving parts of the Rotavator or parts which may be hot from operation.
Check oil levels whilst the Rotavator is running.
- Carry out adjustments or repairs to a mounted Rotavator unless the tractor engine is stopped and the Rotavator firmly supported or lowered to the ground.
- Leave the tractor seat unless the Rotavator is lowered, the pto drive disengaged, the gear shift in neutral, the brake applied, the engine stopped and the ignition key removed

**BE A SAFE OPERATOR BY THINKING –
BEFORE ACTING**

PTO DRIVE SHAFT GUARDS

HOWARD PRODUCTS are supplied with non-rotating PTO Drive Shaft which must be correctly fitted and well maintained.

Before and after each use PTO driven implements should be examined to ensure the Drive Shaft rotates freely in the guards, the guards are undamaged, securely fitted, correctly seated on the shaft grooves and the restraining chains attached to the tractor and implement.

Should the guards be broken, damaged or badly fitted the implement must not be used damaged parts have been replaced and/or bad fitting corrected.

Always ensure the guard tubes do not separate at the PTO Drive Shaft's longest working or transport length, or at it's shortest.

Avoid damage to guards when the PTO Drive Shaft is being connected or disconnected from the tractor by resting it on a support.

Never allow PTO Drive Shaft Guards to fall into the implement or drop to the ground: damage will almost certainly occur.

Always ensure the sliding surfaces of the guard tubes are clean and the guard bearings lubricated.

When replacing worn or damaged sections of the Guard, use special tools available from the makers.

Always follow the fitting, lubrication and maintenance instructions supplied by the makers of the PTO Drive Shaft Guard.



**UNLESS CORRECTLY GUARDED
PTO DRIVE SHAFTS CAN KILL**

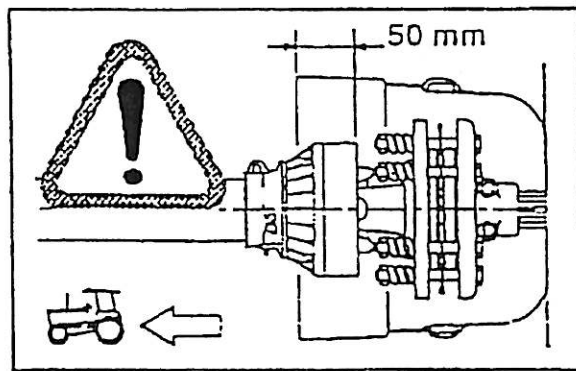

Minimum overlap in straight position

Rotavator 700 / Rotalabour 700

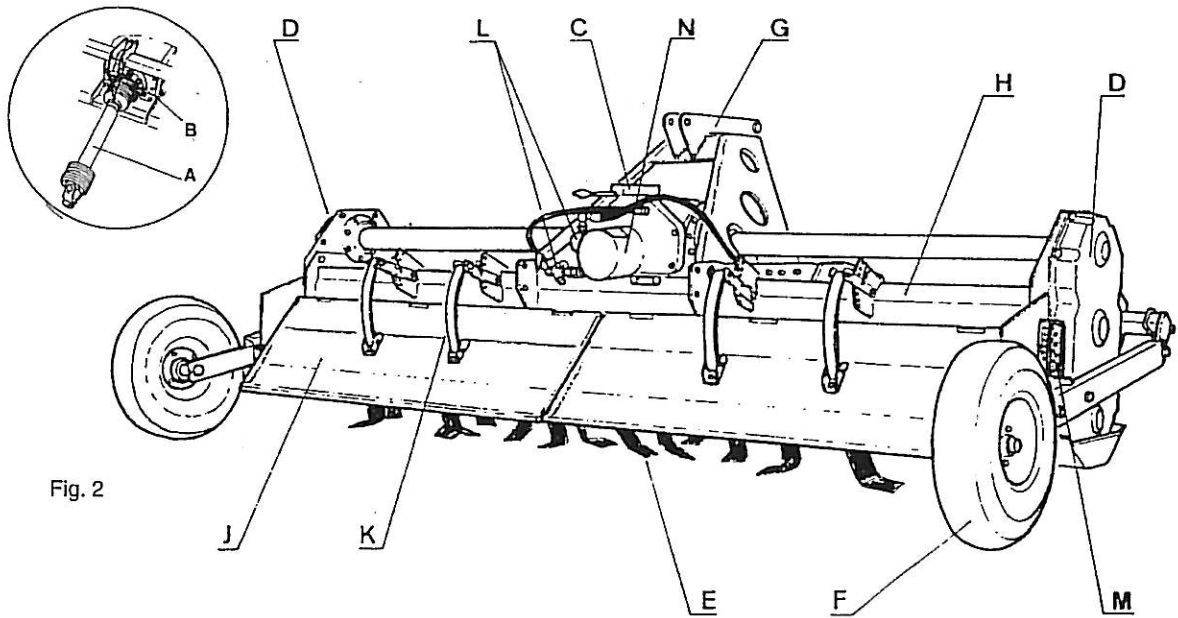

Fig. 2

ENGLISH

Model	Working width cm	Transport width, with packer roller	Speed rpm	Weight Kg	No. of blades	Tractor engine Power HP
R700S-255D	255	309	180 / 210 / 235	1250	60	100-180
R700S-305D	305	359		1400	72	110-190
R700S-355D	355	409		1550	84	120-200
R700S-405D	405	459		1700	96	130-220

SPECIFICATION

The above list shows lists the standard range of Rotavator 700 together with working widths, power requirements and weights.

Description

Fig. 2 indicates assemblies referred to in the text of this manual which are named below :

- A = PTO shaft
- B = Overload Clutch
- C = Lever gear change box
- D = Side Drive (Double)
- E = Rotor
- F = Depth control tyred wheels
- G = Topmast
- H = Hull
- J = Trailing board
- K = Trailing board adjustment
- L = Cooling and lubrication circuit
- M = Depth control system adjustment
- N = Rear PTO 1000 RPM using

Rotavator 700 are designed for 100-220 HP tractors with cat. II or III linkage. The drive is by a PTO shaft from a 1 000 rpm tractor PTO to a multi-speed lever gear change box. Two jackshafts transmit power from the gearbox via the two side drives (with three gears) to the rotor.

The cooling and the lubrication of the Gearbox is assured by a hydraulic pump situated on the rear of the gearbox. An overload clutch provides protection for the transmission. The normal tillage depth of 5-25 cm is adjusted by depth control tyred wheels, or by a roller when used in the ROTALABOUR version. Both are adjusted by means of depth control (M) units.

Rotavator 700 is ideal for general work, such as weed destruction, incorporation of green fertilizers, crop residus and scalping.

Working widths suit large acreage farms for seed bed preparation.

Rotalabour 700 is ideal for:

- Preparation of spring seed beds
- Pasture renovation
- Stubble breaking
- Direct seed bed preparation

In view of these characteristics the Rotavator 700 is the ideal machine for the wide acres and for contractors.

NEW MACHINE

Power Take-Off Drive Shaft & Clutch

For transport purposes PTO shaft are dismantled and must be refitted as instructed below.

Remove the guard (A) from the gearbox. Remove the 9 exposed nuts, washers and springs (B) and the guard (D).
 - Fit the clutch plate (C) and the guard (D) on the 9 exposed bolts and secure with the 9 springs, washers and nuts (See Fig. 3). Tighten the 9 nuts fully to ensure correct seating of the clutch components. Then slacken nuts and locknuts until the springs can easily turn by hand, then adjust the clutch following instructions on p. 21.

- Refit the guard (A)

Lubrication & General

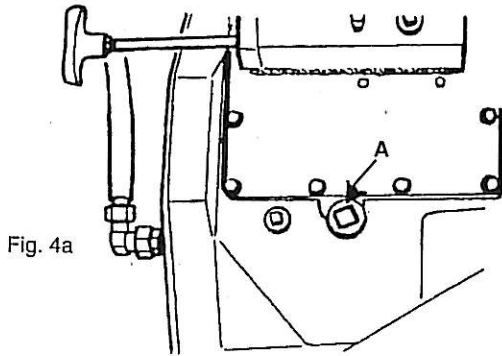
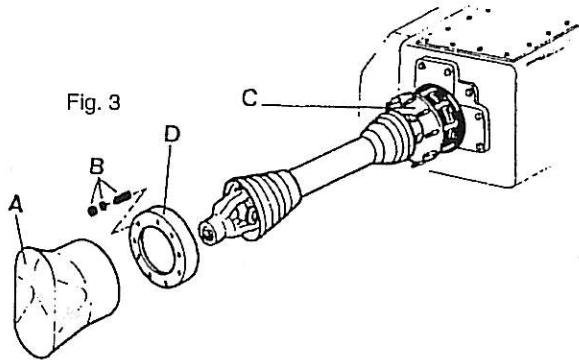

With the machine standing level ensure the following preparatory work has been done:

1. The lever change gearbox filled to the dipstick mark (A) (12 l) - (B) is the draining-plug. See fig. 4a and 4b.
2. The gearcases filled to the level plugs (fig. 5 C) - (7 l). (D) is the draining-plug. See fig. 5.

Total capacity of oil cooling and lubricating system:

R700-255: 32 l.	R700-355: 34 l.
R700-305: 33 l.	R700-405: 35,5 l.

NOTE: Rotavators 700 are supplied with front tube filled with oil.

USE ONLY: SAE 85 W 140 EP

3. All oil and grease points as indicated in page 13 lubrication.
4. All nuts and bolts tightened (re-tighten after first hour's work).

! SERIOUS DAMAGE CAN RESULT FROM FAILURE TO CARRY OUT THE ABOVE PROCEDURES

Attaching the Rotavator to the tractor

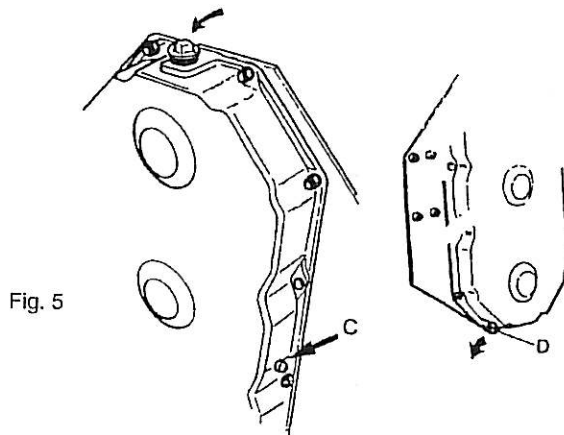
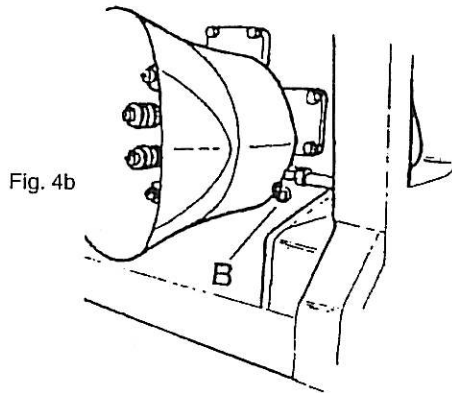

Rotavator 700 / Rotalabour 700

The Rotavator 700 will suit cat.III or II tractors

1. Category III – With quick hitch (see fig. 9 & 10)
2. Category III – Standard (see fig. 12 & 13)
3. Category II – Standard (see fig. 11 & 13)
4. Category III – ASAE standard quick hitch (see fig. 13 & 14)

The PTO Drive shaft must be set to a safe working length

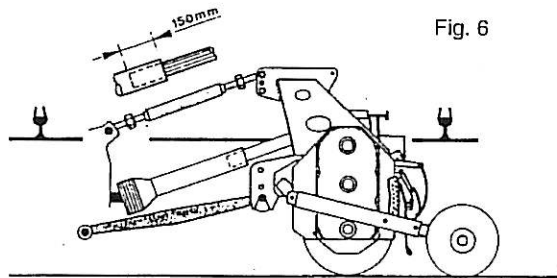

Fig. 6

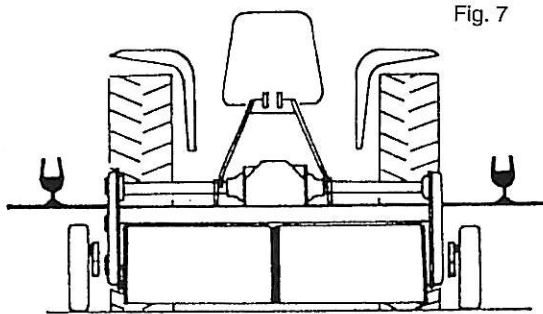

Fig. 7

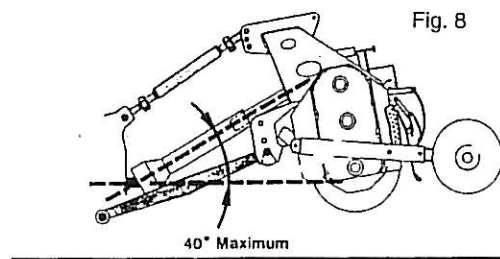

Fig. 8

to ensure the male shaft does not "bottom" or separate from the female tube under all conditions of use and transport. The Rotavator on a firm level surface the Depth Control equipment should be adjusted until the Gearbox Input Shaft is horizontal (see fig.6).

Position the tractor a distance from the Rotavator to give 150 mm (6") minimum engagement of the male half of the PTO Drive Shaft in the female tube when connected to the tractor. This establishes the safe working length of the PTO Drive Shaft for connection to the tractor.

Connect the tractor lower links. Fit the tractor upper link

and secure. Attach the PTO Drive Shaft to the tractor ensuring the quick release pin engages the spline shaft groove. Attach the PTO Drive Shaft Guard Chains to the tractor and Rotavator.

Attach stabiliser bar or check chains to limit sway to 50 mm (2"). Adjust tractor linkage to level the Rotavator laterally and longitudinally (see fig.7).

Before engaging the tractor PTO, lift the Rotavator on the

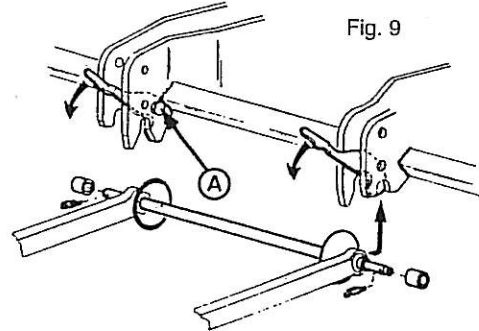

Fig. 9

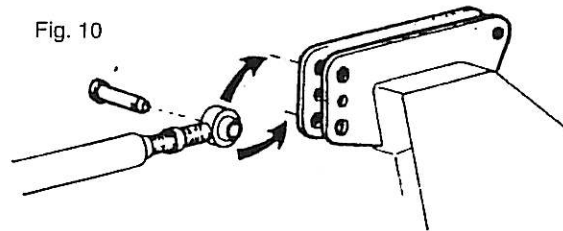

Fig. 10

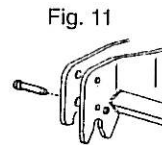

Fig. 11

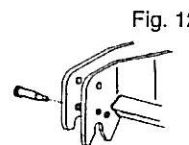

Fig. 12

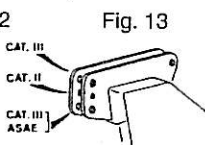

Fig. 13

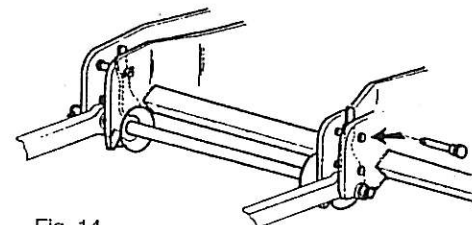

Fig. 14

hydraulic lift linkage until PTO Drive Shaft attains an angle of 40° and set the limit stop on the hydraulic lift control quadrant (see fig.8). THE PTO DRIVE SHAFT ANGLE MUST NEVER EXCEED 40°.

Finally check that during transport and use the PTO Drive Shaft does not "bottom" or separate and that the maximum angle of 40° is not exceeded.

Should it not be possible to obtain the aforementioned settings with your tractor, SEEK ADVICE.

NOTE: when using the linkages mentioned under point 2, 3, 4, remember to remove the locking hooks.

The hook pin (A), fig.9, is locked by a thread-locker (LOCTITE 243) which must be heated to loosen this pin.

LEVER GEAR CHANGE BOX

The 3 speed lever change gearbox permits an easy change of rotor speed. With gears A = 21 teeth and B = 29 teeth (Fig. 15) fitted normally on Rotavator, the following rotor speeds are obtained:

- 1st - 185 RPM
- 2nd = 210 RPM
- 3rd = 235 RPM

Table Fig. 16 shows the different speeds.

NOTE: It is possible to obtain a range of higher speeds by

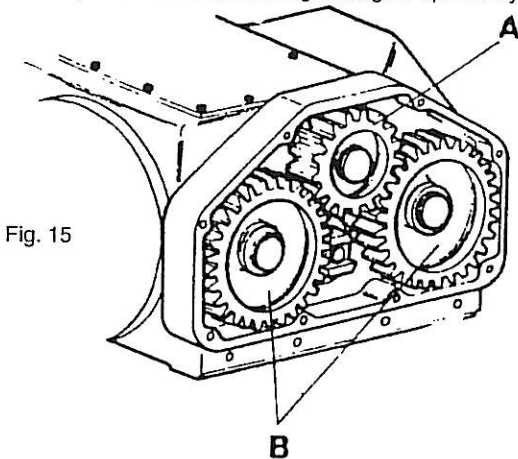

Fig. 15

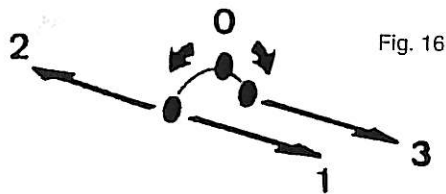

Fig. 16

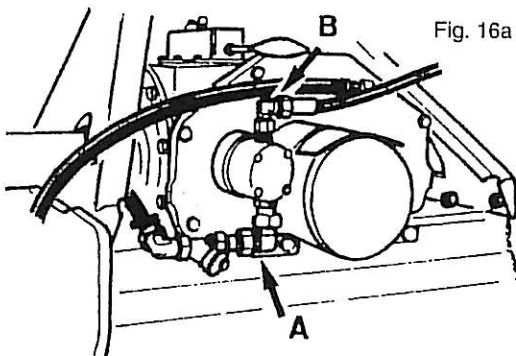
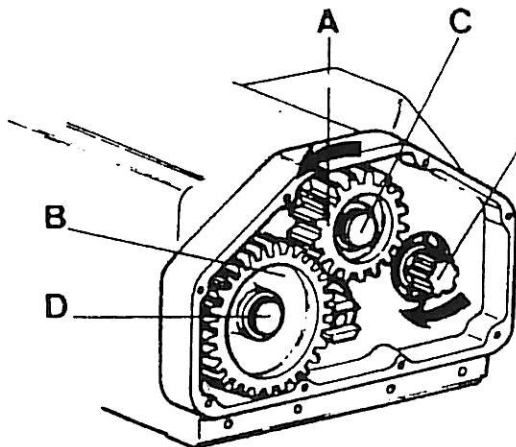

Fig. 16a



using the special gears A = 23 teeth and B = 27 teeth. The higher range of rotor speeds will be:

- 1st - 219RPM
- 2nd = 246 RPM Normally fitted on Rotalabour
- 3rd = 277 RPM

If you change to the special 23-27 teeth gears please read carefully the next chapter giving the instructions concerning adjustment the transmission.

Changing gears (A) and (B)

**STOP THE TRACTOR AND
DISENGAGE THE PTO
BEWARE - OIL & COMPONENTS MAY
BE HOT**

PROCEDURE

- Disconnect the pump at the coupling / joint A&B (fig16).
- Remove this cover
- Remove circlips keeping the gears in position
- Proceed to adjust the transmission by fitting the gears as follows : (see Fig. 17).

1) Fit the small gear (A) on the upper shaft (C) and one of the large gears (B) on the left gear shaft (D). Turn the small gear in the direction indicated on Fig. 17 and the right gear shaft (E) in the opposite direction.

2) Having taken up the play in both side drives, fit the remaining large gear on the right shaft (E) so that one tooth of the small gear (A) drives the large gear (B) without any clearance between the teeth.

This is possible by carefully positioning the large right hand gear on the splined shaft.

If you require to carry out this operation frequently, we advise you to use our special tool n° 000653 136.

- The purpose of the adjustment is to ensure that there is no play in the left and right transmissions. So that on equal sharing of the tractor power is achieved.

The setting is carried out with the rotor resting on the ground.

ROTORS

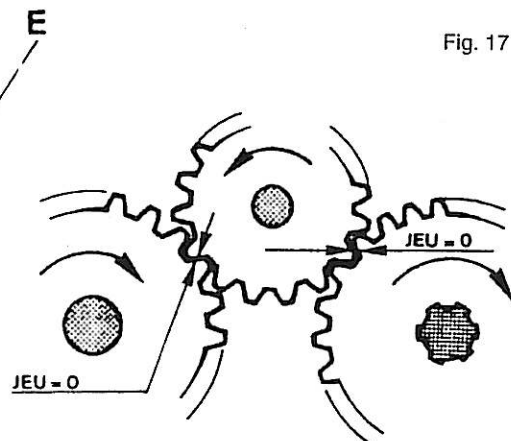
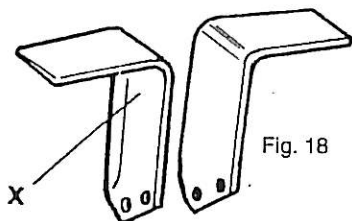
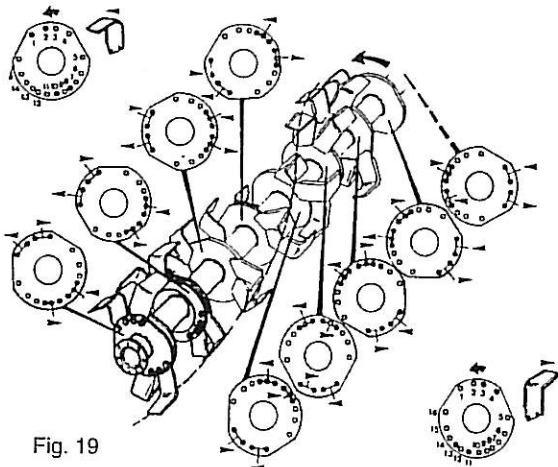

Fig. 17



Badly bent, worn or broken blades will impair efficiency and should be replaced immediately using genuine HOWARD BOLT ASSEMBLIES which are specially manufactured to a high strength specification.



Blading standard rotors

Firstly identify left and right hand blades. Blades X on Fig. 18 is a left hand blade. Use only ORIGINAL-HOWARD-BLADES and HOWARD-BLADE-BOLTS. Always attach blades and clamping rings to the left of the rotor flanges. To blade a rotor to the 2-Blade system refer to Fig.19 and to Fig.20 for the 3-Bladed system proceeding as follows: When correctly fitted, the blades must form a "scroll" pattern. This ensures that they enter the soil at regular intervals to even out the load on the transmission. **When replacing worn blades, remove one blade and fit the new one in it's place before proceeding to the next.** This will ensure that the blade "scroll" pattern is maintained.

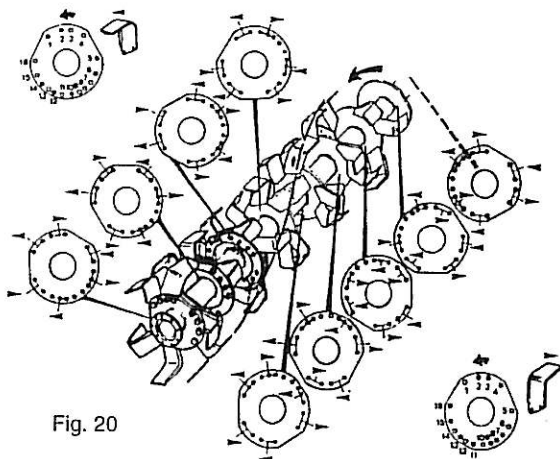

Use only HOWARD blade bolts which have the correct shank length and tensible strength. Fit the bolt head against the blade and the clamping ring and the spring washer and nut against the flange. Tighten the nuts to a torque of 240 Nm.

To help provide alternative tilths the flanges are drilled for either 2 or 3 blade formation which allows for a rougher cloddy finish for overwintering or a finer tilth suitable for spring seed beds.

To simplify changing from one formation to another, each blade bolt hole has a number and the blades are fitted in the following fashion: (see Fig. 19 and 20).

Left hand blades

2 blade formation 1+2; 8+10

3 blade formation 1+2; 5+6; 12+14

Right hand blades

2 blade formation 3+4; 11+13

3 blade formation 3+4; 7+9; 15+16

Note that a left hand blade must precede a right hand on the rotor flanges.

Blading Rotalabour rotors

Firstly identify left and right blades. Blade (x) is a left hand blade and (Y) right hand. (see fig.21)

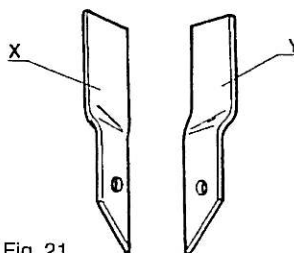

Fig. 21

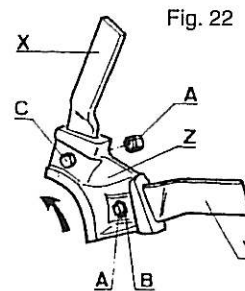

Fig. 22

Changing rotors

To change rotors, the ROTAVATOR should be lifted above the ground on the 3-point linkage and firmly supported for safety.

Take out the 9 bolts (A) securing the rotor to the drive shaft on the left hand side of the machine and the 9 bolts (B) securing the rotor to the drive shaft on the right hand side of the machine.

To fit an alternative rotor reverse the sequence of operations (see fig.23)

In a bracket (Z) for 2 blades (see fig.22), fit the L.H. blades in the first housing in direction of rotation.

NOTE: be careful to put the nut into the hexagonat housing (B) against the blade.

Tightening torque: 200 N-m

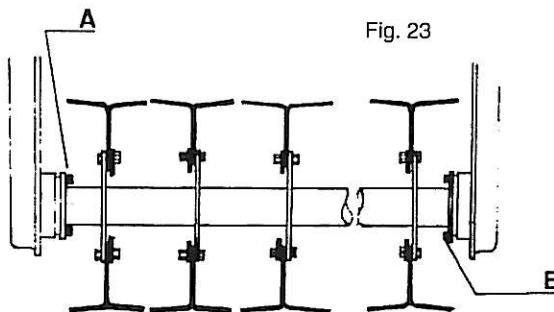

Fig. 23

ENGLISH

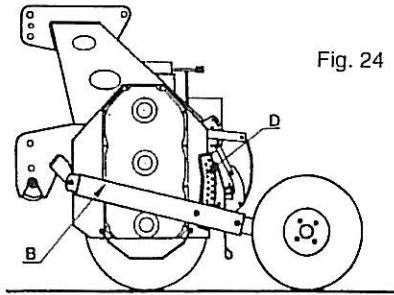

Fig. 24

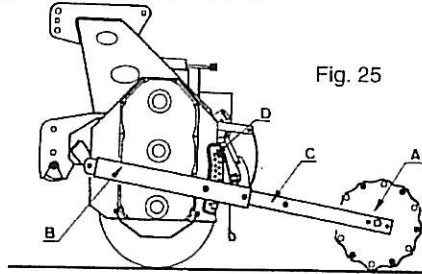

Fig. 25

Depth control

Tillage depth is regulated by side mounted tyred wheels or by a rear mounted crumble roller (fig.24 & 25)

Fig.25 illustrates the attachment of the crumble roller (A) mounting arm (B), the extension arm (C) and depth control system (D).

Crumble rollers can be replaced by depth control wheel, which incorporate the own mounting arms.

NOTA: the side wheels can be fitted in outer or inner side of the arm.

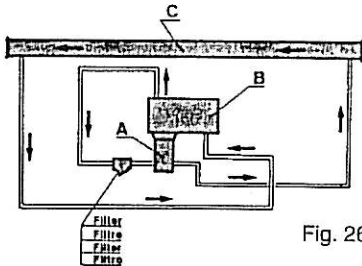

Fig. 26

Cooling and lubricating circuit

The cooling and the lubricating of the lever change gearbox are ensured by a hydraulic system (see fig.26)

Oil is sucked from the gearbox (B) through the oil filter and pumped into the front tube (C) before coming back into the gearbox (B).

Parking prop

To support the machine when it is not attached to the tractor two parking props are fitted on the front bar. When the machine is attached to the tractor linkage the prop should be raised.

TOOTHED ROLLER USE

Mounting the roller on the machine

- Mount the machine on the tractor and lower on to level ground.
- Position the roller near to the machine. **Never lift the roller by the middle of the scraper bar.**
- Fit the roller arms on the roller side plates H by inserting on each side one or two spacers G (2mm thickness). Leave the bolts C loose, but tighten the center screw E with its spacer.

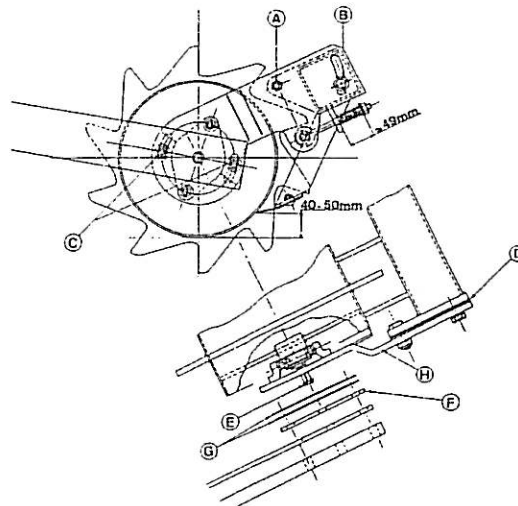

- Fit the roller arms into the machine arms. Ensure that the arm slide freely. If not, increase or decrease the number of spacers G (2mm). Position the roller arms to the required length and tighten the arms (4 bolts M 16).

Adjusting the scrapers

- Check that both depth control arms are at the same level.
- With the machine and the roller on a firm level surface, rotate the scraper bar in order to position the scrapers at 40 to 50mm from the bottom of the roller tube. Check that the scraper bar is parallel to the roller. Tighten the bolts C.
- Ensure that all scrapers touch the roller tube. The pressure setting of the scrapers on the roller tube is obtained by releasing the two bolts B and by adjusting the length of the spring (49mm). Then, re-tighten the bolts B.
- Drive the tractor with the roller lowered on a hard surface in order to scrape off the paint and to verify that the scrapers do not bite into the metal.

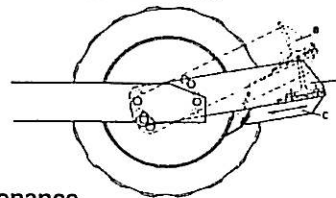

Daily maintenance

- Check every day, the tickness of the layer of soil adhering to the roller tube. If the tickness exceeds 2mm, adjust the scraper bar:
- Release the bolts B.
- Pivot fully the bar to clean scrapers and tube
- Adjust the springs to the nominal length (49mm) re-tighten the bolts B
- When all scrapers are correctly adjusted, it is not necessary to adjust each scraper individually. Simply adjust the scraper bar until the scrapers are completely worn to the angle point and have to be replaced.
- The tension of the spring may be modified according to soil conditions.
- In the same way, the height of the scrapers to the soil surface can be adjusted for various soil conditions, by pivoting the scraper bar (bolts C) without adjusting the scrapers. Ensure that the scraper bar remain parallel to the roller tube.
- It is important to follow all these instructions. An incorrect adjustment could give poor quality results or block the roller.
- After the season, clean the roller and apply oil on the tube.

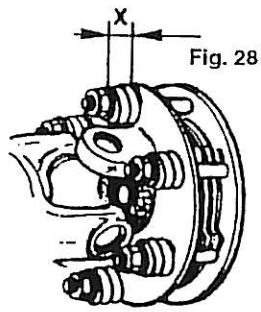
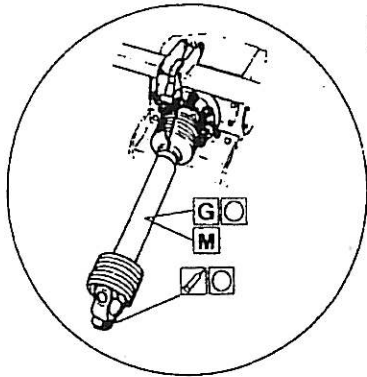
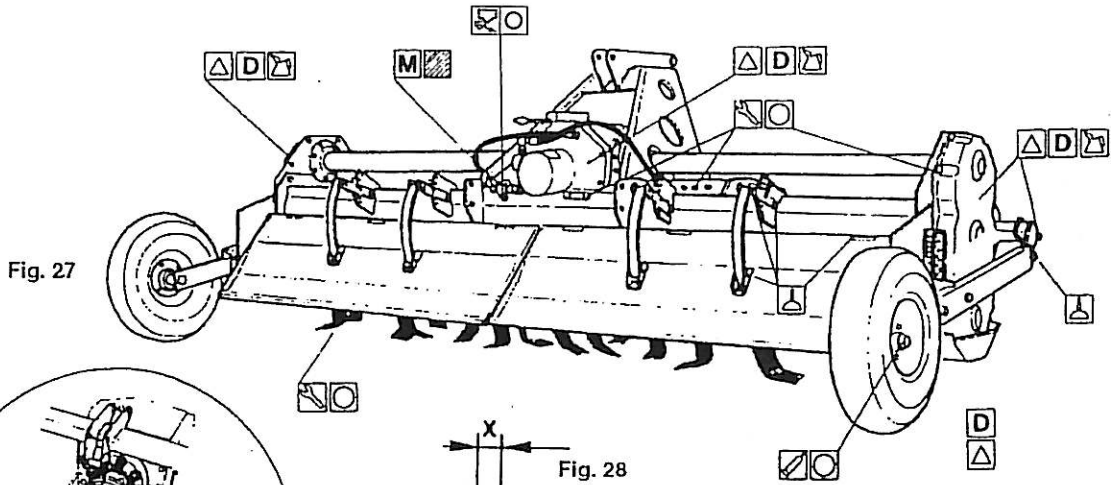

Fig. 29

PTO (1/min)	Tractor H.P. Puissance tracteur (ch) Schlepperklasse (PS) Pot. trattore	X (mm)
1000	100 - 140	35
	140 - 200	34

LUBRICATION + MAINTENANCE (Fig. 27)

- The first 20 hours for work should be done under light load conditions.
- After 50 hours work drain the oil from gearbox, front tube and side drives. Flush with clean paraffin and refill with fresh oil.

NOTE: refill gearbox and front tube by gearbox level plug
 R700-255: 17 l. R700-305: 19 l.
 R700-355: 20 l. R700-405: 21,5 l.

- Replace the level plug
- To set the Rotavator going during a few minutes
- Check oil level
- Clean the gauze filter at pump inlet every 50 hours.

ADJUSTMENTS

Clutch (Fig. 28)

In general the clutch should be adjusted to give drive to the rotor during normal work. Should tree roots, rocks or similar obstacles be struck the clutch must slip to protect the ROTAVATOR and tractor transmission. If the clutch is set too loosely the rotor will turn erratically leading to excessive wear of the friction discs. Conversely a clutch set too tightly provides no protection, transmitting a shock load when obstacles are encountered.

To set the clutch, proceed as follows:

- Take off the guard - Slacken nuts and lock nuts until the springs can easily turn by hand.
- According to the power of the tractor used. Adjust the spring length in accordance with the dimensions given here (turns of nuts and maximum length of springs) (See fig. 28 and 29).

	Daily
	Weekly
	Every 500 hours
	Oil with can
	Top up with Oil SAE 85 W 140EP
	Use grease gun
D	Drain flush and fill SAE 85 W 140EP
G	Apply Graphite or Molybdenum Disulphide Grease
M	Follow makers instructions
	Tighten fasteners
	Clean filter

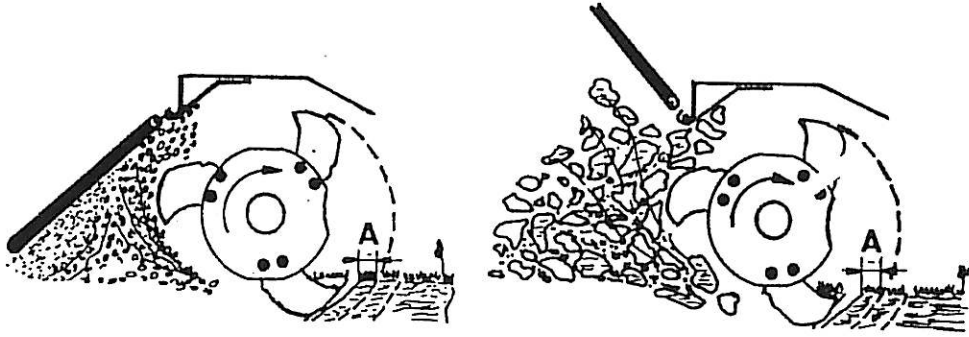

Fig. 30

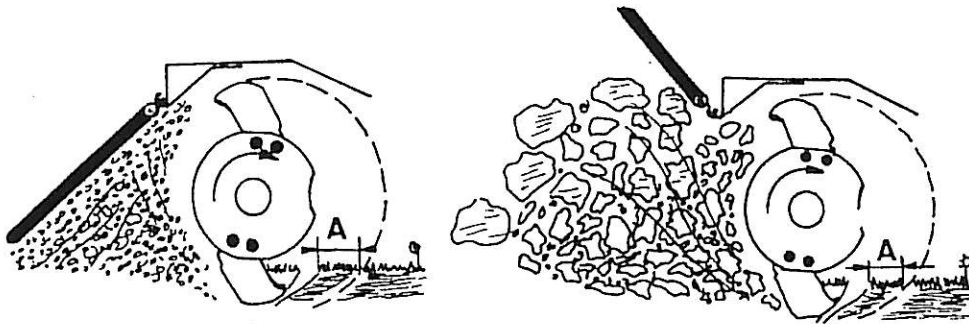

Fig. 31

OPERATING INSTRUCTIONS

Operational Information

By simple adjustments the Rotavator 700 will produce a range of tilths in most soil types and handle various cultivation techniques e.g. weed control, seedbed preparation, trash and chemical incorporation etc.

As a general principle fine tilths are produced by a combination of slow tractor speeds, fast rotor speeds and a lowered trailing board. Conversely, coarse tilths are produced by fast tractor speeds, slow rotor speeds and a raised trailing board (see Fig.30).

As an alternative to the standard 3-blade a 2-blade rotor configuration can be used which reduces the tendency for clogging and soil balling (see Fig. 31). The 2-blade configuration is specially suited to sticky soil conditions, trash incorporation and the production of a rough cloddy finish.

Intermediate grades of tilth from coarse to fine can be obtained by:

1. Varying the rotor speed with a Lever change Gearbox (see page 11 for detailed instructions).
2. Adjusting the height of the trailing board which by impact shatters the blade-cut "clods" (A). Raised trailing boards also deposit weeds and trash on the surface to wither, whilst lowered trailing boards bury trash as well as having a levelling effect on the soil.
3. Increasing or decreasing the tractor travel speed which alters the size of blade-cut "clods" (A). Higher travel speeds may also be used for shallow work on previously broken ground or scalping passes for weed control.

Working Instructions

Set the depth control equipment to the required tillage depth (page 15 a 17). Select a trial trailing board position and rotor speed (Level change Gearbox) to give the type of tilth required. Engage the tractor PTO and drive forward, progressively lowering the Rotavator into the ground. Proceed for a short distance and check whether the resultant tilth is satisfactory and the tillage depth is uniform across the rotor width. If not, make the appropriate adjustments to produce the required tilth utilising the slowest rotor speed which allows for a reasonable ground coverage. Fast rotor speeds demand more power and increase blade wear leading to less economic operation.

If in doubt consult the Operators Checklist page 25 which provides remedies for most operational problems.

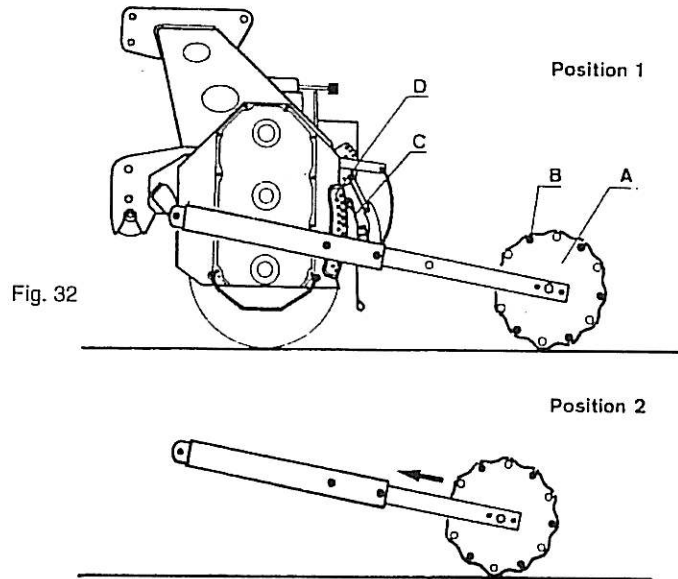

Fig. 32

ROTALABOUR USE

The ROTALABOUR is equipped with a special rotor fitted with twisted blades and a rear crumple roller (A) which also serves as a depth control (D).

The principal use of this implement is soil preparation, levelling and seed bed preparation in one pass. This is achieved by the combination of : rotor, blades, articulated trailing board (C) and roller, which break down and gauge the clod size and distribution to obtain a seed bed suitable for the crop to be sown.

NOTE: When using this machine in wet or heavy soil conditions, it is advisable to remove the alternative bars(B) on the roller to avoid balling-up.

See Fig. 32. Crumple roller with two positions (I) and (II).

OPTIONAL EQUIPMENT

Hydraulic Combi-Hitch

The Rotavator can be fitted with a hydraulic combi hitch as an option, this enables the weight of the mounted implement to be transferred nearer the tractor when is transported, in the raised position the mounted implement is lifted over the top of the Rotavator.

Care has to be taken when attaching the implement to the combi hitch that the rams do not foul any bracketry. A safety pin (A) can be fitted to securely lock the hitch when in the raised transport position. See Fig. 34.

Rear PTO

The rear PTO enables the turbine of gear mounted seed drills and other equipment to be driven.

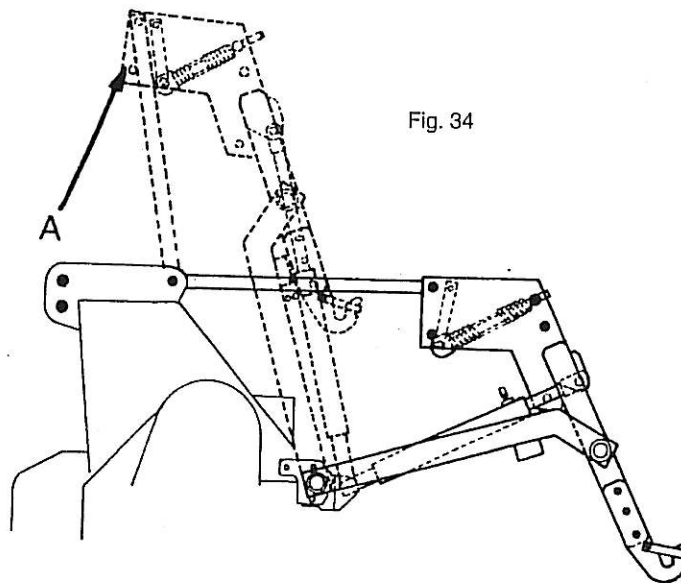

Fig. 34

Operational advice

Insufficient Depth Obtained

- (a) adjust depth control equipment
- (b) insufficient power : use lower tractor gear, reduce rotor speed
- (c) chaincase on hard soil. Further passes required
- (d) blades "trowelling" (rolling over ground), increase rotor speed or use lower tractor gear
- (e) blades incorrectly mounted

Tilth too fine

- (a) raise trailing boards
- (b) reduce rotor speed
- (c) use a faster tractor gear
- (d) convert to 2-blade configuration

Tilth too coarse

- (a) lower trailing boards
- (b) increase rotor speed
- (c) use lower tractor gear
- (d) wait until soil is drier if sticks
- (e) convert to 3-blade configuration

Blades "Ballinq up" with soil

- (a) ground too sticky for working
- (b) increase rotor speed
- (c) raise trailing boards
- (d) decrease tractor speed (e) convert to 2-blade configuration

Excessive Blade Wear

- (a) reduce rotor speed
- (b) replace loose or bent blades

Rotavator "Bumping" on Ground

- (a) obstacles entangled in blades
- (b) blades incorrectly mounted with no scroll effect or blades fitted with blunt edge leading or broken blades

Obvious Points

- (a) ROTAVATOR not level - cutting too deep on right side. Shorten right hand tractor lift rod or adjust depth control wheel (b) Not overlapping - drive closer to last run
- (c) Working on hillsides. Work up the slope if possible. If lateral work cannot be avoided, work from the top to the bottom in order to limit any terracing effect.

Rotavating

1. When operating the Rotavator the most suitable practice is to work in "lands"
2. The ROTAVATED ground should always be to the right of the driver.
3. ROTAVATING the field headlands should not be carried out until the "lands" have been completed.
4. Always raise the Rotavator before turning.



THE ROTAVATOR SHOULD NEVER BE LOWERED WHILST THE TRACTOR IS TURNING.